

# P39 Standard Gas Regulators

- Spare valve disks provided. Each unit comes with a 4 seat valve disk block. This block can be easily rotated 90° to provide a fresh valve disk sealing surface.
- Easily changed from tamper-resistant to T-handle adjustment or vice versa.
- Both adjustment assemblies are supplied with every unit.
- Brass casing material

The BelGAS P39 regulator selection is the largest of its type in the industry. We offer this regulator in three different materials, one of which will ideally suit your application AND your budget. ALL of the P39's are offered with six different spring ranges. Our broad selection of outlet pressure spring ranges allows more precise regulation of downstream pressure, hence, better process control. Piping designs can be simplified by using any one (or all) of the 3 outlet ports that come standard on the regulator. The BelGAS P39 is the ONLY regulator of this type, which has 3 outlet ports. To enhance the versatility of this regulator further, we provide you with a choice of seat materials that allows the designer to custom fit the seat material with the application.



## Applications

- First cut of high-pressure natural gas to control valve supply
- Natural gas instrumentation columns
- First cuts to any downstream, low flow application, such as catalytic heaters, valve actuators, pressure controllers and chemical injection pumps



## Specifications

Inlet	1/4 NPT	
Outlet	1/4 NPT (3 Ports)	
Vent	4 holes (5/32" each) (STD)	
	1/4 NPT (Tapped Vent Option)	
Max Inlet	5500 PSIG, 379 BAR	
Orifice Size	5/64"	
<b>Outlet Ranges</b>		
	0 – 30 PSIG	2.1 BAR
	0 – 60 PSIG	4.1 BAR
	0 – 120 PSIG	8.3 BAR
	0 – 150 PSIG	10.3 BAR
	0 – 225 PSIG	15.5 BAR
Temp. Range	-40° F to 225° F	-46° C to 106° C
<b>Weight Approximate</b>		
Standard	3-1/4 lbs	1.46 kg
500 PSIG	3-3/4 lbs	1.69 kg

## Flow Charts

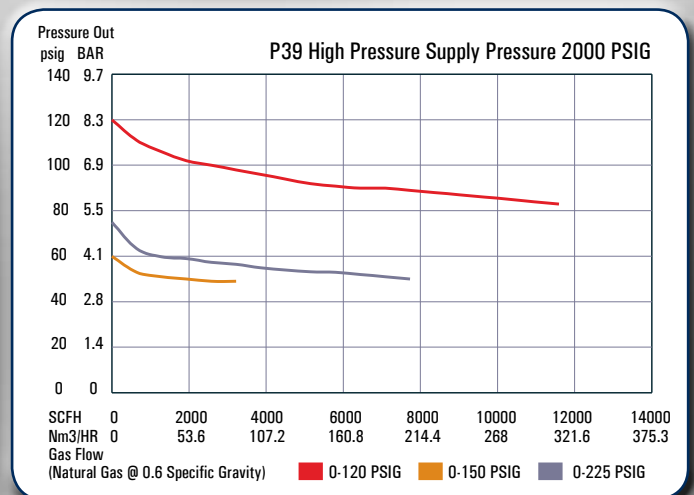
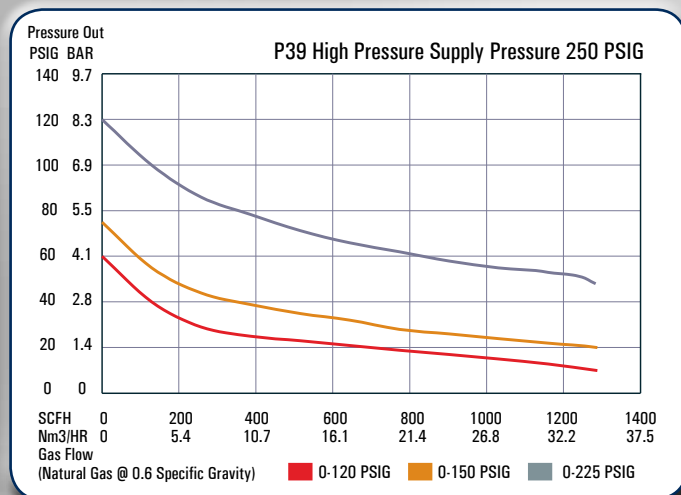

## P39 Standard Part Matrix

<b>P03902</b>		<b>0</b>	<b>X</b>	<b>0</b>			<b>0</b>	
	↑	↑	↑	↑	↑	↑	↑	Spring Range
	<b>030</b>							0-30 PSIG      0-2.1 BAR
	<b>060</b>							0-60 PSIG      0-4.1 BAR
	<b>120</b>							0-120 PSIG     0-8.3 BAR
	<b>150</b>							0-150 PSIG     0-10.3 BAR
	<b>225</b>							0-225 PSIG     0-15.5 BAR
								Version
		<b>0</b>						Standard
								Adjustment Method
			<b>X</b>					T-Bar and Adjustment Screw (Allen Head) with Tamper Resistant Cover
								Vent
				<b>0</b>				Standard Untapped Bonnet Vent
								Seat Material
					<b>1</b>			Nylon
					<b>3</b>			Teflon
								Port Configuration
						<b>0</b>		Standard
								Casing Material
							<b>0</b>	Brass

## Materials of Construction

Brass Unit	
Body, Bonnet, Bottom Plug	Brass
Tamper Resistant Cover	Brass
Diaphragm	302 Stainless
Seals	TFE, Nitrile
Valve Spring	17-7 <sup>PH</sup> Stainless Steel
Range Spring	Spring Steel, Chrome Silicon
Seat Material	Nylon or TFE

## P39 Standard Dimensions

Dimensions Table		A	B	C	D
P39 w/T-Handle 0-30, 0-60, 0-120, 0-150, 0-225 PSIG range	mm	156	58	85	64
	inches	6.14	2.3	3.33	2.50
P39 w/Allen Head 0-30, 0-60, 0-120, 0-150, 0-225 PSIG range	mm	150	58	85	19
	inches	5.90	2.30	3.33	0.75

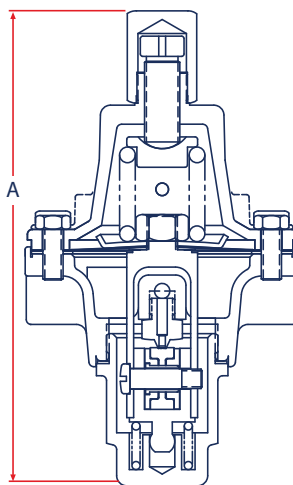
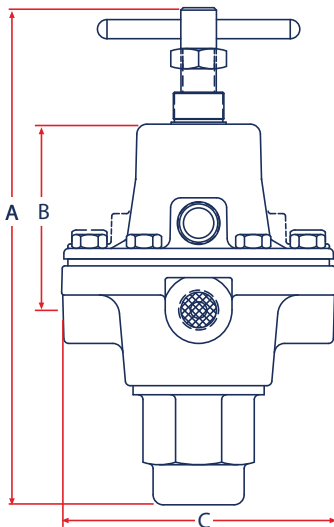
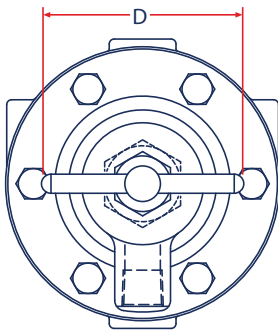

## Ports

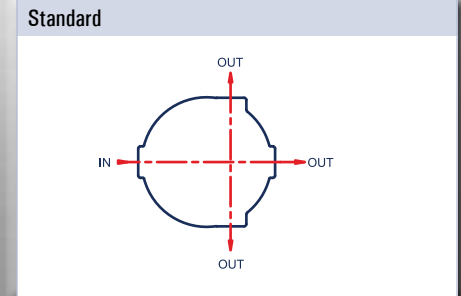

# P39 Special Build Gas Regulators

## Specials include these models:

- 500 PSI Outlet
- Dual Inlet Ports
- Nickel Plated and Stainless Steel
- Tapped Vent Models



## Applications

- First cut of high-pressure natural gas to control valve supply
- Natural gas instrumentation columns
- First cuts to any downstream, low flow application, such as catalytic heaters, valve actuators, pressure controllers and chemical injection pumps

## P39 Special Build Part Matrix

P03902		↑	↑	↑	↑	↑	↑	↑	Spring Range
	<b>030</b>								0-30 PSIG 0-2.1 BAR
	<b>060</b>								0-60 PSIG 0-4.1 BAR
	<b>120</b>								0-120 PSIG 0-8.3 BAR
	<b>150</b>								0-150 PSIG 0-10.3 BAR
	<b>225</b>								0-225 PSIG 0-15.5 BAR
	<b>500</b>								0-500 PSIG 0-34.5 BAR
Versions									
	<b>0</b>								Standard
	<b>3</b>								PED (for EU)
	<b>4</b>								ENVIRO-Cap* (Water Jacket) *Not available in Stainless Steel
Adjustment Method									
	<b>0</b>								T-Bar
	<b>1</b>								Adjustment Screw (Allen Head) with Tamper Resistant Cover
Vent Options									
	<b>0</b>								Standard Bonnet *Not available in Brass or Nickel 500 PSIG units.
	<b>1</b>								Tapped Vent Bonnet* Tapped vent is standard on Stainless Steel 500 PSIG units.
Seat Material									
	<b>1</b>								Nylon
	<b>3</b>								Teflon (Brass units only) *Nickel and Stainless Steel only
	<b>4</b>								PTFE*
Port Configuration									
	<b>0</b>								Standard **Not available in Stainless Steel
	<b>1</b>								Dual Inlet**
Casing Material									
	<b>0</b>								Brass
	<b>1</b>								Electroless Nickel
	<b>2</b>								Stainless Steel

## Materials of Construction

Brass Unit	
Body, Bonnet, Bottom Plug	Brass
Tamper Resistant Cover	Brass
Diaphragm	302 Stainless
Seals	TFE, Nitrile
Valve Spring	17-7 <sup>th</sup> Stainless Steel
Range Spring	Spring Steel, Chrome Silicon
Seat Material	Nylon or TFE
Nickel Plated Unit	
Body, Bonnet, Bottom Plug	Nickel Plated Brass
Tamper Resistant Cover	Nickel Plated Brass
Diaphragm	302 Stainless Steel
Seals	TFE, Nitrile
Valve Spring	17-7 <sup>th</sup> Stainless Steel (Nickel Plated)
Range Spring	Spring Steel or Chrome Silicon
Seat Material	Nylon or PTFE (316 SS Block)
Stainless Steel Unit	
Body, Bonnet, Bottom Plug	316 Stainless Steel
Tamper Resistant Cover	316 Stainless Steel
Diaphragm	Monel 400
Seals	TFE, Neoprene
Valve Spring	MP35N (UNS30035)
Range Spring	Spring Steel
Seat Material	Nylon or PTFE (316 SS block)

Only the P39SS Conforms to NACE MR0175



## Specifications

Inlet	1/4 NPT	
Outlet	1/4 NPT (3 Ports)	
Vent	4 holes (5/32" each) (STD)	
	1/4 NPT (Tapped Vent Option)	
Max Inlet	5500 PSIG, 379 BAR	
Orifice Size	5/64"	
Outlet Ranges		
	0 – 30 PSIG	2.1 BAR
	0 – 60 PSIG	4.1 BAR
	0 – 120 PSIG	8.3 BAR
	0 – 150 PSIG	10.3 BAR
	0 – 225 PSIG	15.5 BAR
	0 – 500 PSIG	34.5 BAR
Temp. Range	-40°F to 225°F	-46°C to 106°C
Weight Approximate		
Standard	3-1/4 lbs	1.46 kg
500 PSIG	3-3/4 lbs	1.69 kg

## Ports

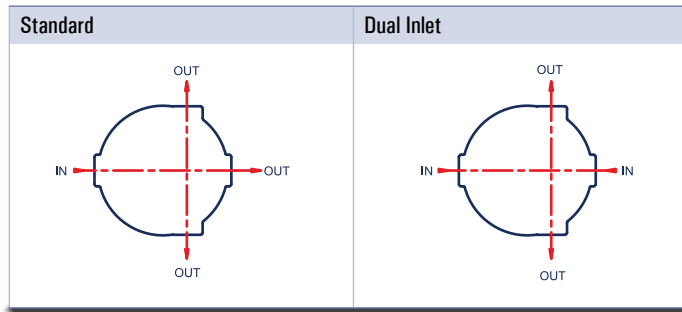

## P39 Special Build Gas Dimensions

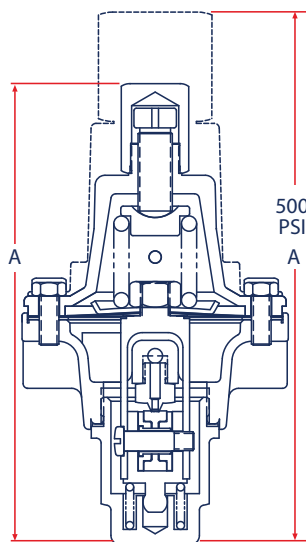
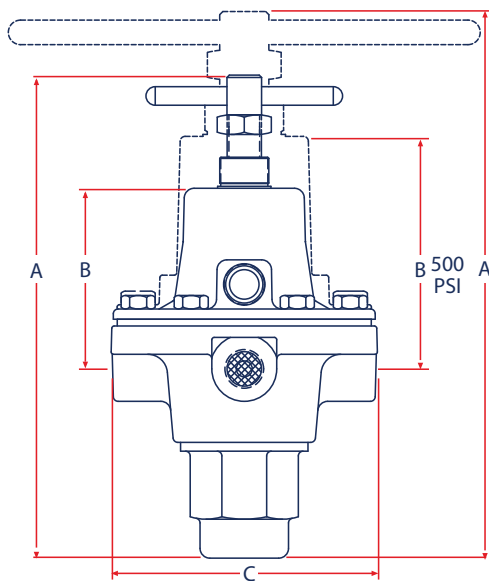
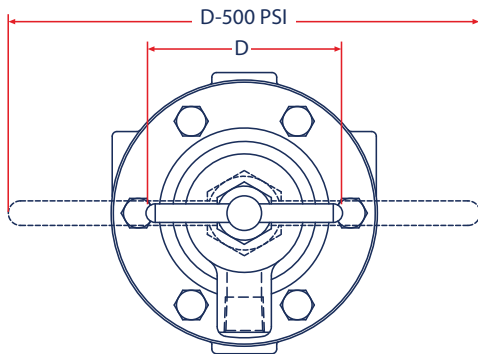

Dimensions Table		A	B	C	D
P39 w/T-Handle 0-30, 0-60, 0-120, 0-150, 0-225 PSIG range	mm	156	58	85	64
	inches	6.14	2.3	3.33	2.50
P39 w/Allen Head 0-30, 0-60, 0-120, 0-150, 0-225 PSIG range	mm	150	58	85	19
	inches	5.90	2.30	3.33	0.75
P39 w/T-Handle 0-500 PSIG range	mm	177	75	85	152
	inches	6.98	2.96	3.33	6.0
P39 w/Allen Head 0-500 PSIG range	mm	172	75	85	32
	inches	6.78	2.96	3.33	1.25