

Natural Gas & Propane Regulators

P32 Superior regulation and excellent stability make the P32 Regulator ideal for lower flow applications. Square head adjustment screw allows for easy in-field calibration. The P32 is available with handwheel adjustment, output pressure gauge and/or mounting bracket as options. The use of a relief valve is recommended for this product in accordance with NFPA 58.

- 60-mesh screen
- UL listed (Standard P32)
- NACE construction available
- Harmful particles blocked
- Non-Relieving

P36 This reliable precision preset regulator is ordered with the exact pressure regulation required. Ideal for areas requiring tamper resistant components or where incidental re-adjustment is a concern. The use of a relief valve is recommended for this product in accordance with NFPA 58.

- 60-mesh screen
- Dripwell option
- UL listed (Standard P36)
- NACE construction available
- Harmful particles blocked
- Release undesirable moisture
- Non-Relieving

P37 The P37 contains many of the same characteristics as the P38, but at a reduced price. At 110 SCFM (16.5 Mbtu/hr), the P37 offers flow rates comparable to current market suppliers. The use of a relief valve is recommended for this product in accordance with NFPA 58.

- Balanced pintle design
- Bubble tight/non-relieving
- 16.5 Mbtu/hr. (110 scfm)
- UL listed
- Bellofram Rolling Diaphragm
- High flow capacity
- Enclosed space use
- High volume applications
- Non-Relieving

P38 The P38 uses a patented balanced pintle design which eliminates unsteady changes in outlet pressure due to inlet pressure fluctuations. The P38 is a spring opposed, diaphragm - operated, non-relieving regulator. The use of a relief valve is recommended for this product in accordance with NFPA 58.

- Balanced pintle design
- Bubble tight/non-relieving
- 27 Mbtu/hr (260 scfm)
- UL listed
- Bellofram Rolling Diaphragm
- Exceptional flow capacity
- Enclosed space use
- High volume applications
- Minimal effect on output pressure from variation of supply pressure

Applications

- Pneumatic Controllers
- Valve Positioners
- Actuation
- Fuel Gas
- Compressed Air



Specifications

	P32	P36	P37	P38
Sensitivity	1" water column	1" water column	1" water column	1/2" water column
Max. Inlet Pressure	250 PSIG (17 BAR)	250 PSIG (17 BAR)	400 PSIG (28 BAR)	400 PSIG (28 BAR)
Port Size	1/4 NPT	1/4 NPT	1/2, 3/4 NPT	3/8, 1/2, 3/4, 1 NPT
Outlet Ranges	0-10, 0-30, 0-60, 0-120 PSIG (0-0.7, 0-2, 0-4, 0-8 BAR)	0-20, 20-40, 40-60 PSIG (0-1.4, 1.4-2.8, 2.8-4 BAR)	0-10, 0-30, 0-60, 0-125 PSIG (0-0.7, 0-2, 0-4, 0-8 BAR)	0-30, 0-60, 0-125 PSIG (0-2, 0-4, 0-8 BAR)
Adjustment	Adjustment Screw	None	T-Bar	T-Bar
Materials of Construction	Aluminum, Brass, Plated Steel, Buna-N	Aluminum, Brass, Plated Steel, Buna-N	Zinc, Aluminum, Plated Steel, Buna-N, Brass	Zinc, Aluminum, Plated Steel, Buna-N, Brass
Diaphragm Material	Nitrile Elastomer with Polyester Fabric	Nitrile Elastomer with Polyester Fabric	Nitrile Elastomer with Polyester Fabric	Nitrile Elastomer with Polyester Fabric
Approximate Weight	0.85 lbs, 0.38 kg	0.70 lbs, 0.32 kg	1.4 lbs, 0.63 kg	5.0 lbs, 2.25 kg

P32, 36, 37 & 38 Part Matrix

P0							0	0	0
	↑	↑	↑	↑	↑	↑			
	32								Regulator
	36								P32 regulators
	37								P36 regulators
	38								P37 regulators
									P38 regulators
									Body Size
	02								1/4" P32 & P36 only
	03								3/8" P38 only
	04								1/2" P37 & P38 only
	06								3/4" P37 & P38 only
	08								1" P38 only
									Spring Range (see 'NOTE' for P36)
	010								0-10 PSIG 0-0.7 BAR P32 & P37 only
	030								0-30 PSIG 0-2 BAR P32, P37, P38
	060								0-60 PSIG 0-4.1 BAR P32, P37, P38
	120								0-120 PSIG 0-8.3 BAR P32 only
	125								0-125 PSIG 0-8.6 BAR P37 & P38 only
									* NOTE: For P36 Enter the preset value in PSIG, Example: 10 PSIG = 010 Minimum Pressure = 2 PSIG Maximum Pressure = 60 PSIG
									Special Construction
	0								None
	1								Epoxy Paint P37 & P38 only
	2								Tapped supply port for gauge P38 only
	3								Both options 1 & 2 P38 only
	4								PED Version (for EU) P32, P37 & P38 only
	5								Tapped vent P32, P37 & P38 only
	6								Options 1 & 5 P37 & P38 only
									Adjusting Method
	0								No Option P36, P37 & P38 only
	1								Adjusting Screw P32 only
	2								Handwheel P32 only
									Versions
	0								Standard
	N								NACE P32 & P36 only

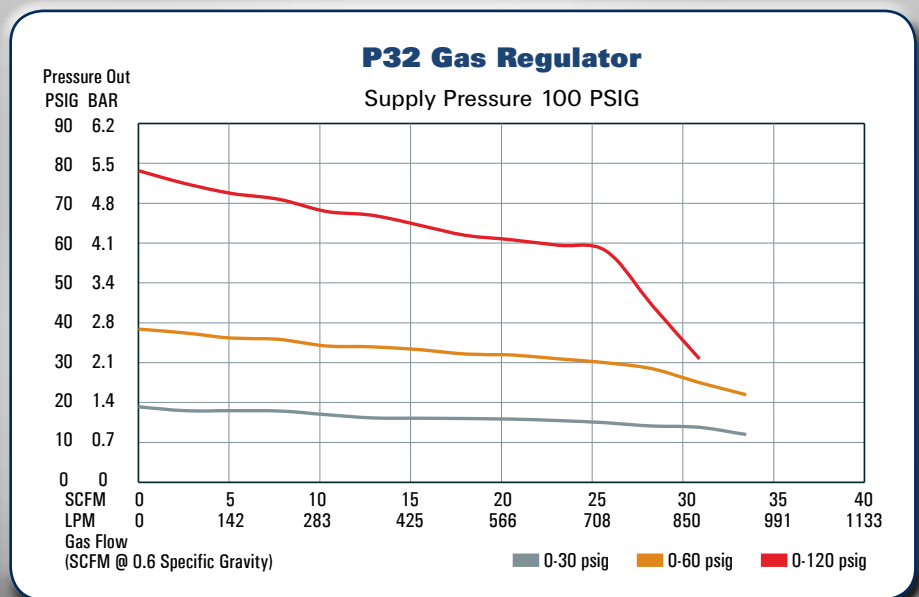

P36 Gas Regulator

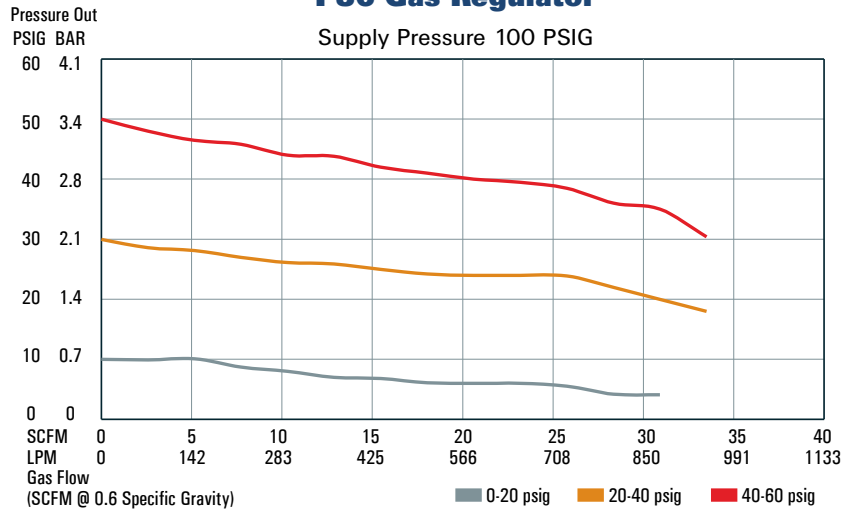

P37 Gas Regulator

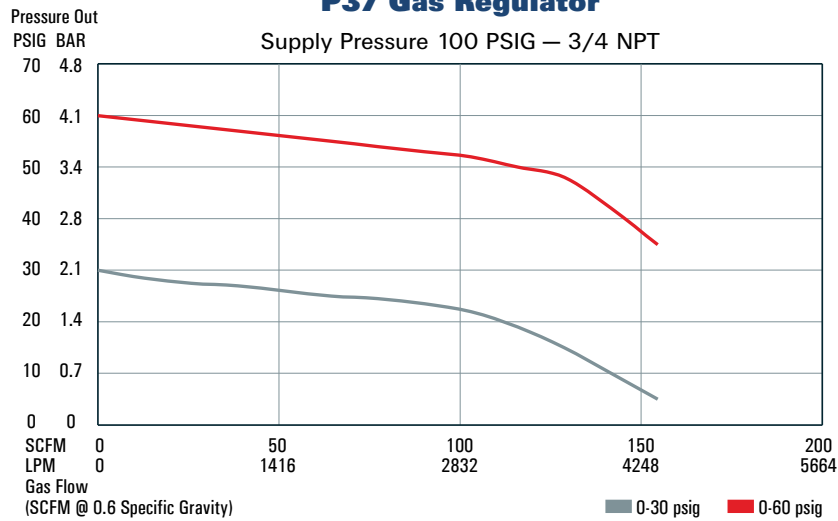

P38 Gas Regulator

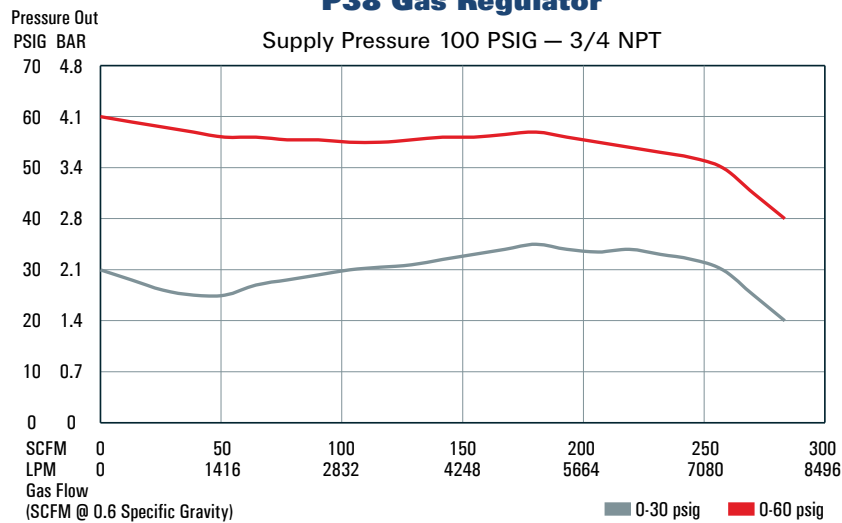

P32 Dimensions

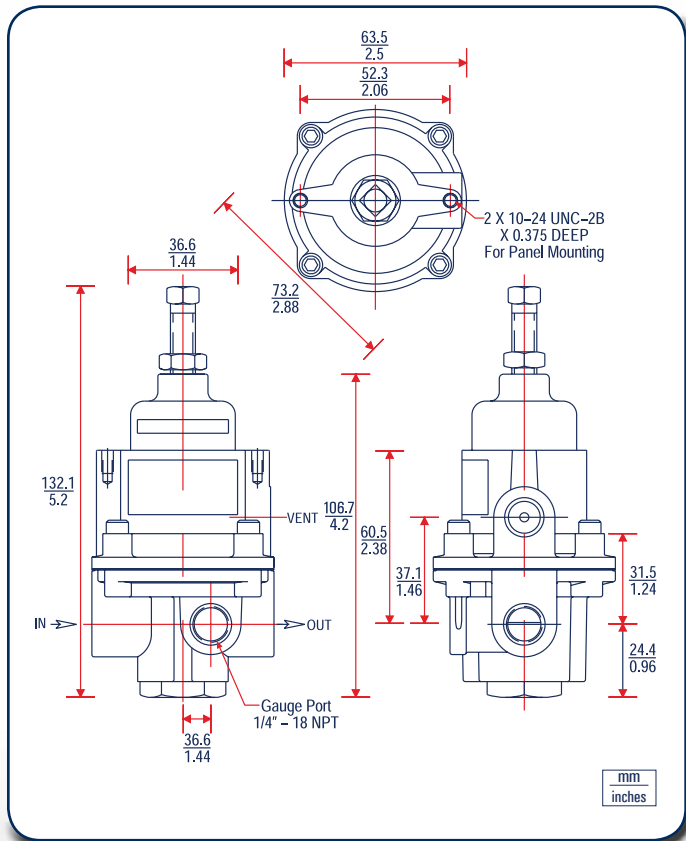

P37 Dimensions

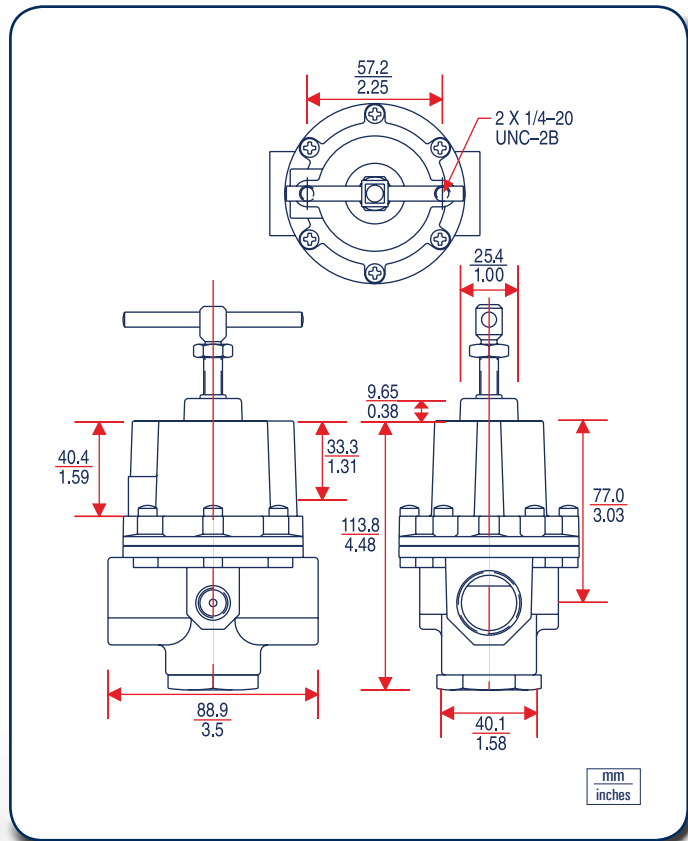

P36 Dimensions

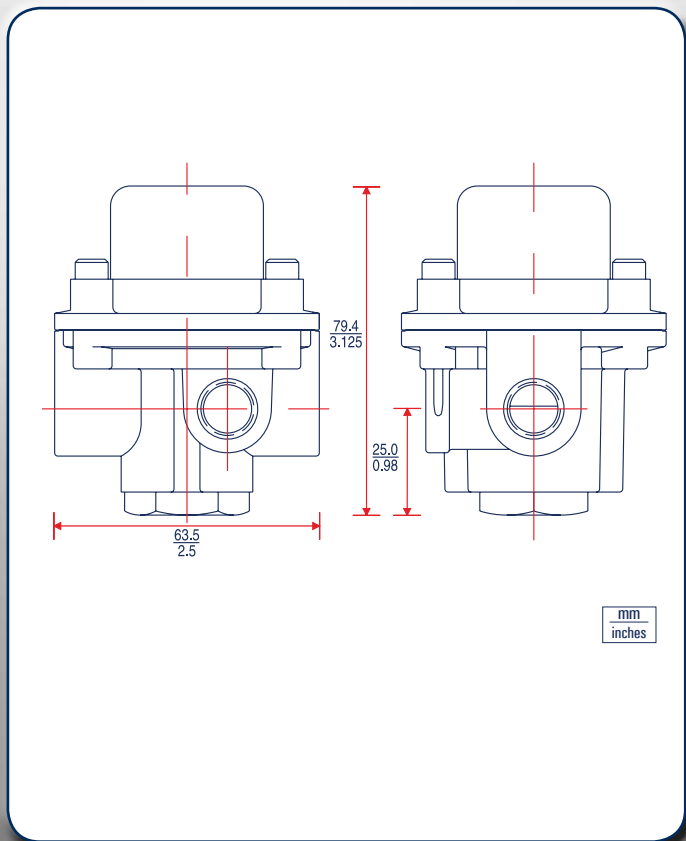

P38 Dimensions

